



SERIAL VOICE SRAM (128K · 1 BIT)

GENERAL DESCRIPTION

The W55206B is a normal speed, low power CMOS static RAM organized as 128K × 1 bit that operates on a single 5V power supply. Manufactured using Winbond's high performance CMOS technology, the W55206B is designed for extensive use in voice recording applications.

FEATURES

- Single 3.6V to 5.5V power supply
- Low power consumption
- Fully static operation
- Low data retention voltage
- Easy to cascade

PIN CONFIGURATION

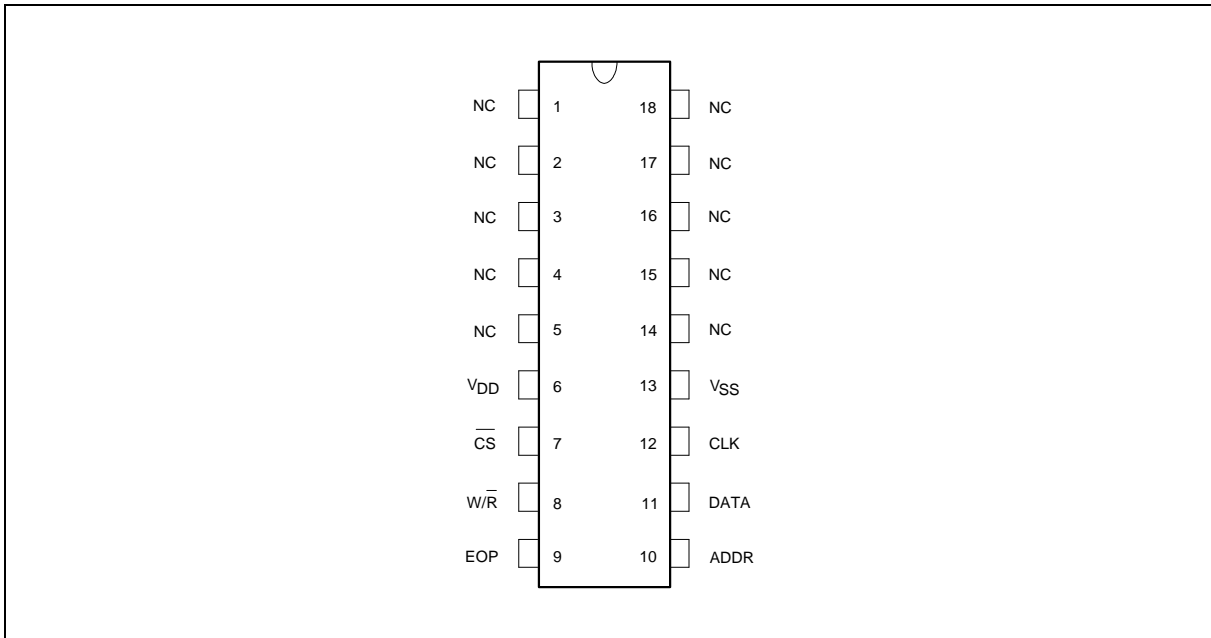

PIN DESCRIPTION

NO.	PIN	I/O	DESCRIPTION
6	VDD	PWR	Positive power supply
7	$\overline{\text{CS}}$	I	Chip-inhibit for $\overline{\text{CS}} = 1$; chip-select for $\overline{\text{CS}} = 0$ or open (with internal pull-low resistor)

Pin Description, continued

NO.	PIN	I/O	DESCRIPTION
8	$\overline{W/R}$	I	Write-in control for $\overline{W/R} = 1$, read-out control for $\overline{W/R} = 0$
9	EOP	O	End signal output
10	ADDR	I	Clock input for start address
11	DATA	I/O	Bidirectional data pin
12	CLK	I	Clock input for address increment
13	Vss	PWR	Ground

BLOCK DIAGRAM

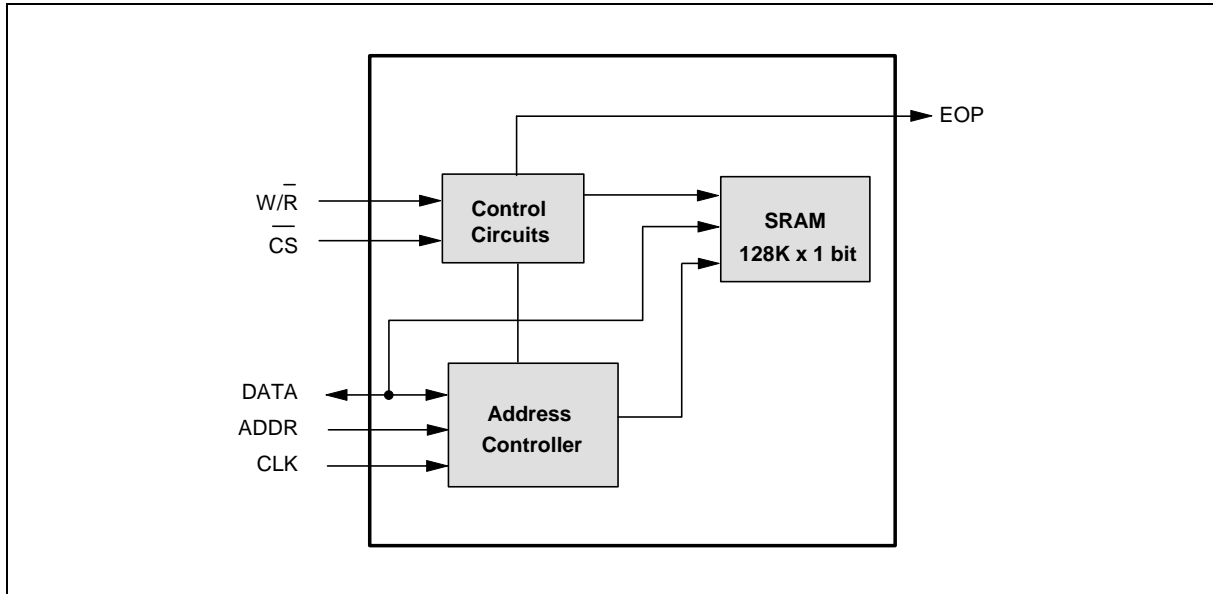

FUNCTIONAL DESCRIPTION

• TRUTH TABLE

\overline{CS}	$\overline{W/R}$	MODE	DATA PIN	V _{DD} CURRENT
H	X	Not selected	High Z	ISB
L	H	Write	Data in	IOP
L	L	Read	Data out	IOP

- When the chip is unselected, the $\overline{W/R}$ signal will be transmitted to the EOP pin.
- Before a read or write operation, the address counter must be reset by sending an ADDR pulse and setting DATA = 0.



- After power on, the read operation is disabled. A read operation may be performed only after a write operation is completed.
- In write-in operation, the EOP signal will change from low to high and remain high when the final address of the chip is encountered. It will change to low again with the next ADDR pulse.
- In read-out operation, the EOP pin will generate one pulse signal when the final address of the SRAM chip is encountered.

The timing of the loading start address for write-in/read-out operations is shown below:

- Load start address for write-in/read-out operations:

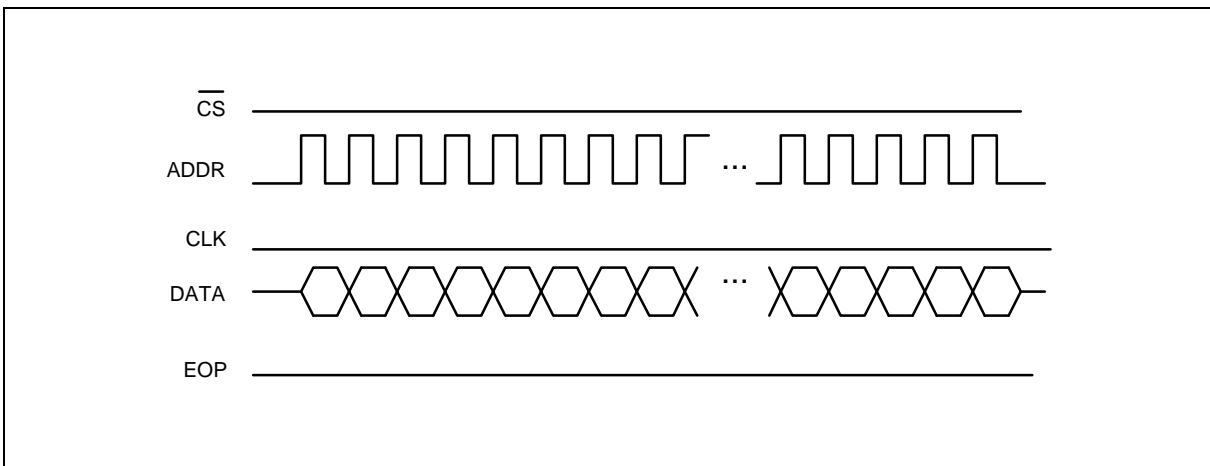

- Write-in operation:

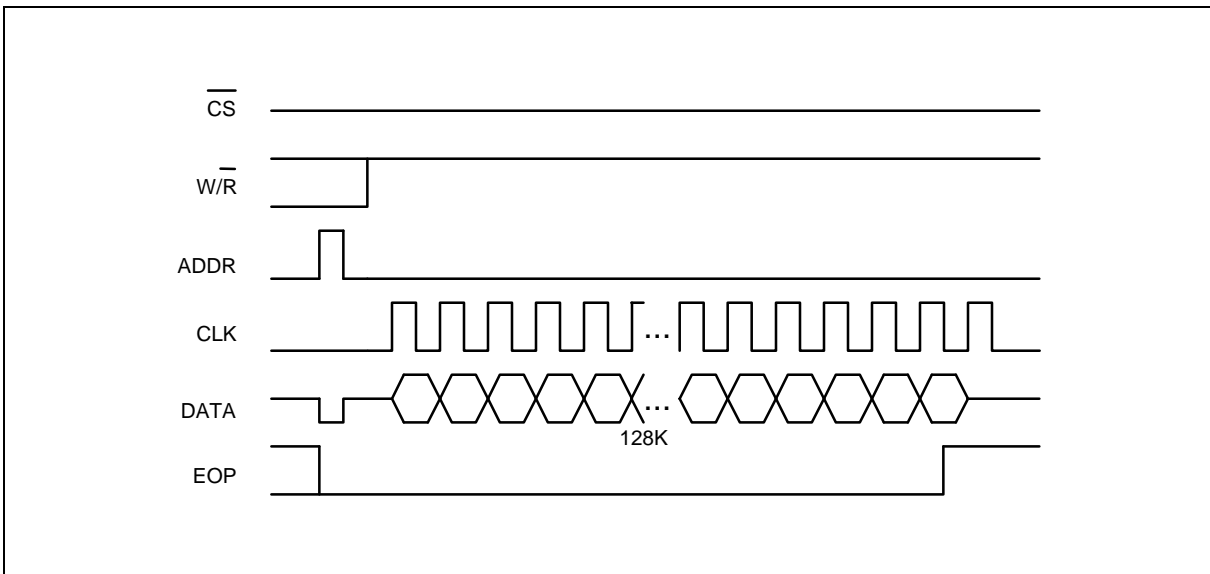



- Read-out operation:

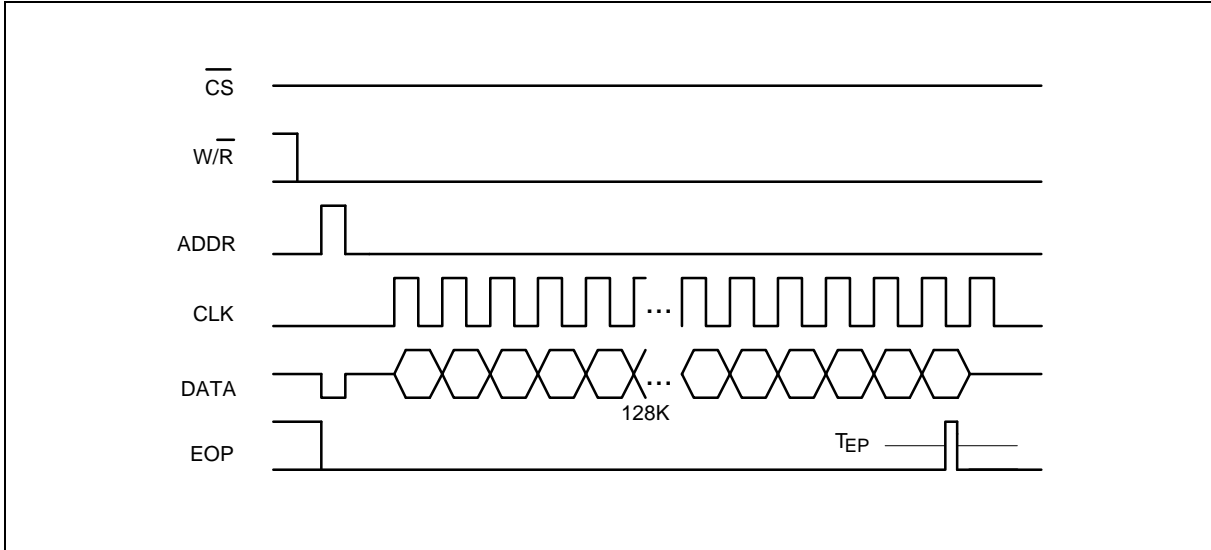

- No operation (standby)

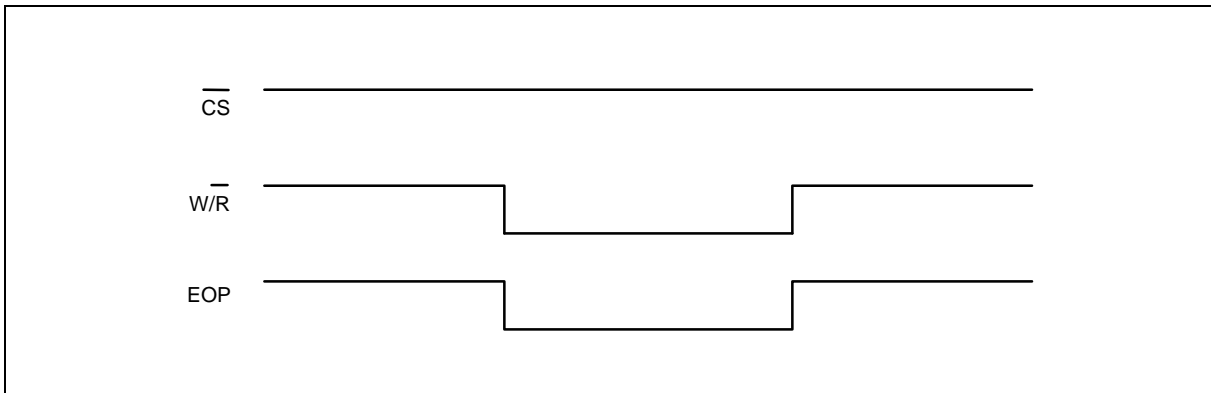

ABSOLUTE MAXIMUM RATINGS

PARAMETER	SYMBOL	RATING	UNIT
Supply Voltage	VDD-VSS	-0.3 to +5.5	V
Input Voltage	VIN	VSS -0.2 to VDD +0.2	V
Output Voltage	VO	VSS to VDD	V
Operating Temperature	TOPR	0 to +70	°C
Storage Temperature	TSTG	-55 to +150	°C

Note: Exposure to conditions beyond those listed under Absolute Maximum Ratings may adversely affect the life and reliability of the device.



DC CHARACTERISTICS

T_A = 25° C, V_{DD} = 5.0V, V_{SS} = 0.0V

PARAMETER	SYMBOL	CONDITIONS	LIMIT			UNIT
			MIN.	TYP.	MAX.	
Operating Voltage	V _{DD}	-	3.6	5.0	5.5	V
Operating Current	I _{OP}	F _c = 1 MHz	-	-	15	mA
V _{DD} for Data Retention	V _{DR}	$\overline{CS} \geq V_{DD} - 0.2V$	2.4	-	5.5	V
Data Retention Current	I _{DDDR}	V _{DD} ≥ 3V, $\overline{CS} \geq 2.8V$	-	-	10	μA
Standby Current	I _{SB}	-	-	2	10	μA
Input Voltage (for ADDR, CLK, W/R and \overline{CS} pins)	V _{IH}	-	2.8	-	6.0	V
	V _{IL}	-	-0.5	-	+0.8	
Input Current (for \overline{CS})	I _{IH}	V _I = 5.0V	-	-	5	μA
Output Current (for EOP)	I _{OH}	V _O = 4.0V	4	6	-	mA
	I _{OL}	V _O = 0.8V	-4	-8	-	

AC CHARACTERISTICS

T_a = 25° C, V_{DD} = 5.0V, V_{SS} = 0.0V

PARAMETER	SYMBOL	CONDITIONS	MIN.	TYP	MAX.	UNIT
Clock Frequency (for CLK and ADDR)	F _C	-	-	-	1	MHz
Data Hold Time	T _{WH}	Write mode	0	-	-	nS
Data Hold Time	T _{RH}	Read mode	0	-	-	nS
Data Hold Time (for ADDR)	T _{AH}	-	0	-	-	nS
Data Access Time	T _{RA}	Read mode	-	-	80	nS
Data Setup Time	T _{WS}	Write mode	250	-	-	nS
Data Setup Time (for ADDR)	T _{AS}	-	250	-	-	nS
EOP Pulse Width (for ADDR)	T _{EP}	Read mode	100	-	-	nS
High Level Duration of Clock for CLK and ADDR	T _H	-	400	-	-	nS
Low Level Duration of Clock for CLK and ADDR	T _L	-	600	-	-	nS
W/R Signal Setup Time for Write Mode	T _{SUR}	-	300	-	-	nS
W/R Signal Setup Time for Write Mode	T _{SUW}	-	300	-	-	nS
Time Width Between ADDR and CLK Clock	T _D	-	1	-	-	μS

TYPICAL APPLICATION CIRCUIT (For reference only)

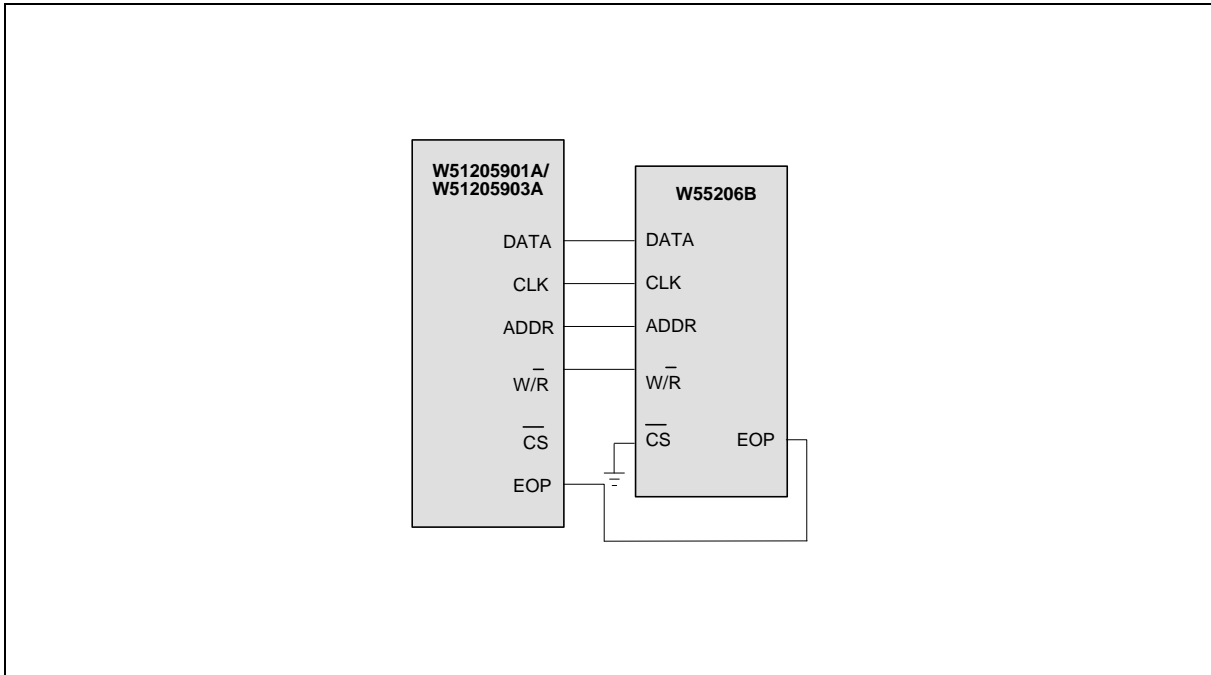

* W51205901A/W51205903A substrate connected to Vss for C.O.B.

* W55206B substrate connected to VDD for C.O.B.



Headquarters

No. 4, Creation Rd. III,
Science-Based Industrial Park,
Hsinchu, Taiwan
TEL: 886-3-5770066
FAX: 886-3-5792697
<http://www.winbond.com.tw/>
Voice & Fax-on-demand: 886-2-7197006

Taipei Office

11F, No. 115, Sec. 3, Min-Sheng East Rd.,
Taipei, Taiwan
TEL: 886-2-7190505
FAX: 886-2-7197502

Winbond Electronics (H.K.) Ltd.

Rm. 803, World Trade Square, Tower II,
123 Hoi Bun Rd., Kwun Tong,
Kowloon, Hong Kong
TEL: 852-27513100
FAX: 852-27552064

Winbond Electronics North America Corp.

Winbond Memory Lab.
Winbond Microelectronics Corp.
Winbond Systems Lab.

2730 Orchard Parkway, San Jose,
CA 95134, U.S.A.
TEL: 1-408-9436666
FAX: 1-408-9436668

Note: All data and specifications are subject to change without notice.